

Booster Pump and Ejector Nozzle Selection

Introduction:

Hydro Instruments offers a standard nozzle for each of our ejectors. However, we also offer alternate nozzle choices for each ejector. Each nozzle will have different operation requirements for water flow and pressure. Each installation will have different hydraulic conditions and the site specific conditions must be understood and considered when selecting the ejector and nozzle. A booster pump may or may not be required in order to operate the ejector.

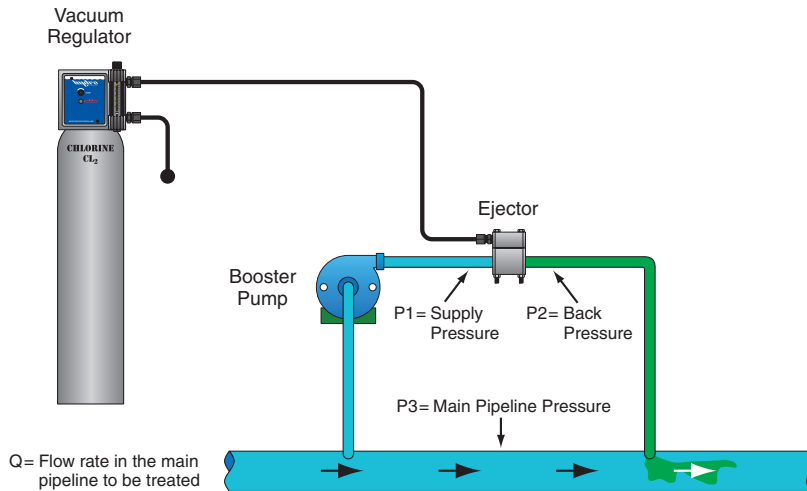

NOZZLE SIZING CHART (10 kg/hr)

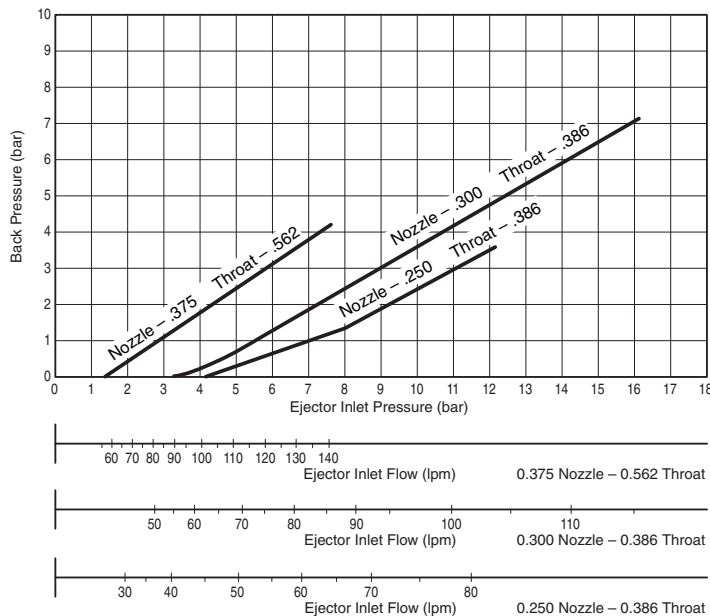

Table of Contents

Sections	Page
I. Terms and Units Conversions	3
II. Site & System Information Required	3
III. Using Ejector Performance Curves	4
IV. Consider hydraulic conditions	4
V. Ejector maximum back pressure	4
VI. Booster Pumps	5
VII. Specific Examples	6
 Figures	
1. Injection into pressurized pipe with booster pump	3
2. Booster Pump diagram and performance curve	5
3. Typical water well installation with booster pump	6
4. EJ-1000 Ejector performance curve (1000 gr/hr)	7
5. EJ-5000 Ejector performance curve (10 kg/hr)	7
6. Open tank installation with booster pump	8

I. Terms and Unit Conversions

NOTE: Consider the following drawing for the locations of P1, P2, and P3.

P1 – We refer to this as the “supply pressure” because this is the water pressure at the inlet of the ejector.

P2 – We refer to this as the “back pressure” because it is the water pressure at the exit of the ejector.

P3 – We refer to this as the “process pressure”.

Q – Process Water Flow Rate

Figure 1: Injection into pressurized pipe with booster pump

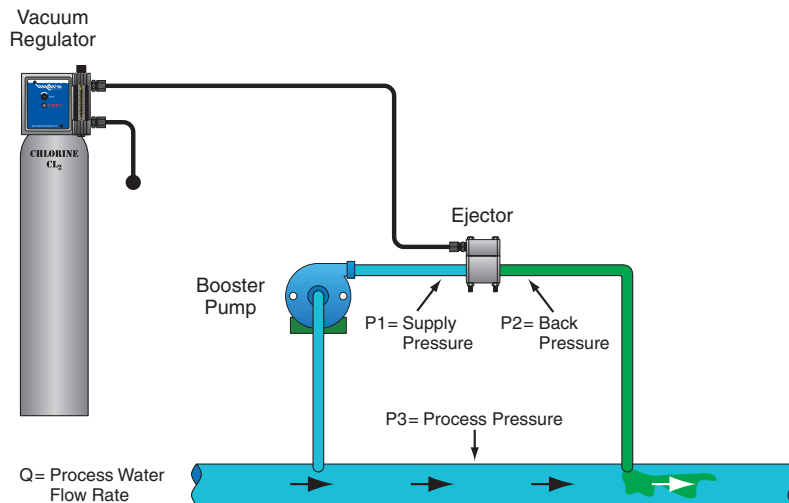

Unit Conversions:

1. Pressure:

$$14.5 \text{ PSI} = 1 \text{ bar} = 1 \text{ kg/cm}^2$$

2. Volume:

$$1 \text{ m}^3 = 1,000 \text{ liters}$$

$$1 \text{ gallon} = 3.78 \text{ liters}$$

II. Site & System Information Required

1. P3 Process Water Pressure – This is different for every site and this information can only be obtained from the site.
2. Length of pipe between the ejector and the injection point. This information also is different for every site and must be obtained from the site. Also, consider the size of piping, number of elbows, and any check valves or other items that might be installed in this section of pipe. This information must be obtained and used to estimate the back pressure (P2).
3. Ejector capacity – The ejector capacity required must be determined after knowing the maximum flow rate in the process water to be treated (Q_{MAX}) and the required maximum dosage of chlorine in the treated water (“Dosage” in terms of PPM). Using this information use the following equation to determine the ejector capacity required:

$$[Q_{MAX}(\text{m}^3/\text{hr})] \times [\text{Dosage (PPM)}] \times [1/1000] = \text{Chlorine Gas Feed Rate (kg/hr)}$$

III. Using the Ejector Performance Curves to Determine Ejector Requirements

(Determine P1 ejector supply pressure and ejector water flow.)

NOTE: For high altitude installations it may be necessary to increase the supply pressure beyond the stated minimum requirements on the performance curves. Increasing the supply pressure by 1.0 PSI per 1000 ft. of elevation above sea level is recommended.

1. Knowing the required ejector capacity, find the correct ejector performance curve from Hydro Instruments Catalog or Instruction Manual. (Meaning – if the ejector is a 10 kg/hr ejector, then find the 10 kg/hr ejector performance curve.)
2. Use the estimated ejector back pressure P2 to find the required minimum ejector supply pressure P1 and the required minimum water flow through the ejector.
3. If a lower supply pressure P1 or a lower ejector water flow rate is required, then consider using an alternate nozzle selection with a larger or smaller nozzle size. Larger nozzles will require lower supply pressure, but higher water flow rates. Smaller nozzles will require higher supply pressure, but lower water flow rates.

IV. Consider Hydraulic Conditions (Booster Pump or Water Supply Requirements)

NOTE: The piping at every installation is different. Some installations require a booster pump and others do not.

1. Consider all possible ways to provide the required minimum supply pressure and flow to the ejector that was calculated in the above section. Sometimes there might be water available on site with high enough pressure that it could be used instead of a booster pump.
2. Consider if it is possible to reduce the back pressure because this would also reduce the required supply pressure. In general, moving the ejector closer to the injection point or increasing the diameter of the pipe in this section are the two main ways that this can be achieved.
3. Consider using alternate nozzle sizes. See Section III.3. above.

V. Ejector Maximum Back Pressure

1. Standard ejectors are mostly rated up to a back pressure (P2) of 10 bar (150 PSI).
2. For all ejectors up to 10 kg/hr, Hydro Instruments also offers optional “high pressure ejectors” that can handle back pressures up to 20 bar (300 PSI).
3. Be sure to confirm that the ejector you select is rated to a pressure that matches or exceeds the maximum back pressure that might be experienced.

VI. Booster Pumps

1. There are many types and sizes of booster pumps available. Booster pumps that are designed for continuous long term operation should be used. Centrifugal multi-stage designs are the most common choice. The materials selected should be based on the booster pump manufacturer's suggestion and the customer's specifications.
2. Booster pumps are sized by the power limitation. Each booster pump will have a performance curve that shows the pressure boost at a given water flow rate. As the water flow rate through the pump increases, the pressure boost will decrease. The pump manufacturer should be consulted to confirm the operating condition (pressure and flow) to be used.

IMPORTANT: The output pressure of the booster pump is calculated as the pump inlet water pressure plus the pressure boost of the pump.

3. Booster pumps will have a maximum inlet pressure limitation. Consult the pump manufacturer for this information.

Figure 2: Multi-stage centrifugal booster pump diagram and performance curve

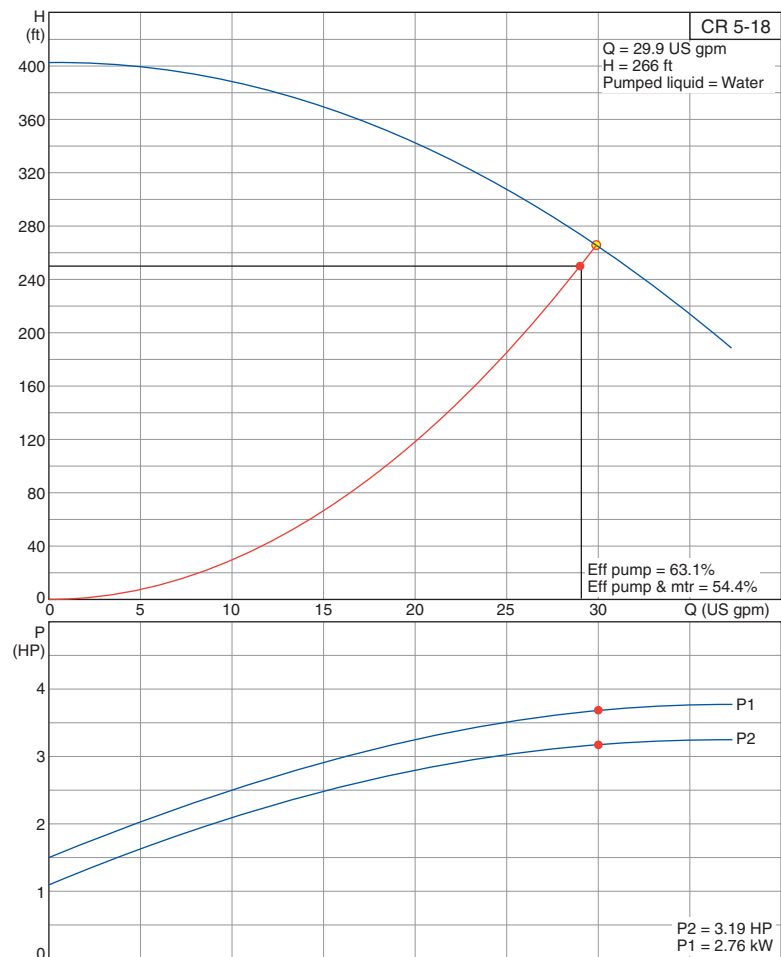

VII. Specific Examples

1. Pressurized Water Pipe injection (such as a water well):

Figure 3: Typical water well installation with booster pump

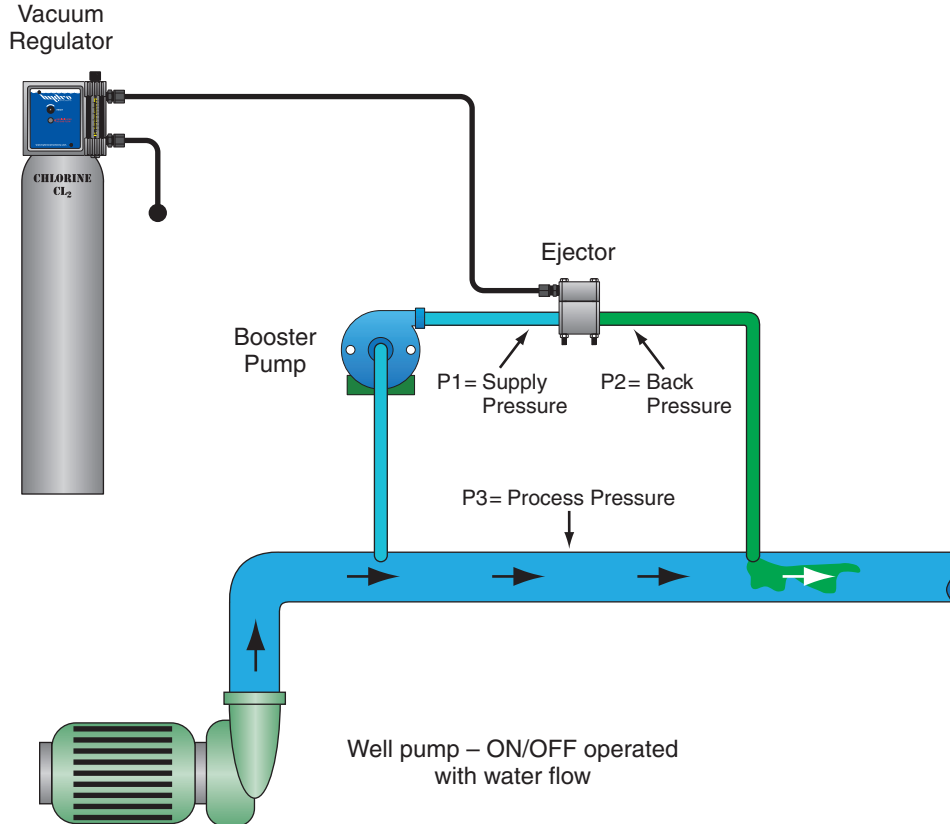

NOTE: In this type of installation, the booster pump will be set to turn on and off with the well pump. In this way, the chlorine gas feed is also turned off and on with the well pump.

- a. Typically the back pressure P₂ is only slightly higher than the main line pressure P₃.
- b. In this example, P₃ = 4 bar. Therefore, we will estimate P₂ = 4.2 bar.
- c. In this example, Q = 400 m³/hr and Dosage = 2 PPM. Therefore, the required chlorine gas feed rate is 800 gr/hr because:

$$[400 \text{ (m}^3\text{/hr)}] \times [2 \text{ PPM}] \times [1/1000] = 0.8 \text{ kg/hr} = 800 \text{ gr/hr}$$
 Therefore, we could select a 1000 gr/hr Model EJ-1000 ejector.
- d. Looking at the 1000 gr/hr ejector performance curve (See Figure 4 below) with the standard #2 nozzle, using the back pressure P₂ = 4.2 bar, we can see that the minimum required supply pressure P₁ = 7 bar and the minimum water flow rate is 35 liters/minute (2.1 m³/hr).
- e. Since the booster pump inlet pressure P₃ = 4 bar and the required supply pressure P₁ = 7 bar, the booster pump requirement is 3 bar (= 7 bar – 4 bar). The booster pump must produce a pressure boost of at least 3 bar when the booster pump flow rate is 2.1 m³/hr.

Figure 4: Standard ejector performance curve for the EJ-1000 Ejector (1000 gr/hr).

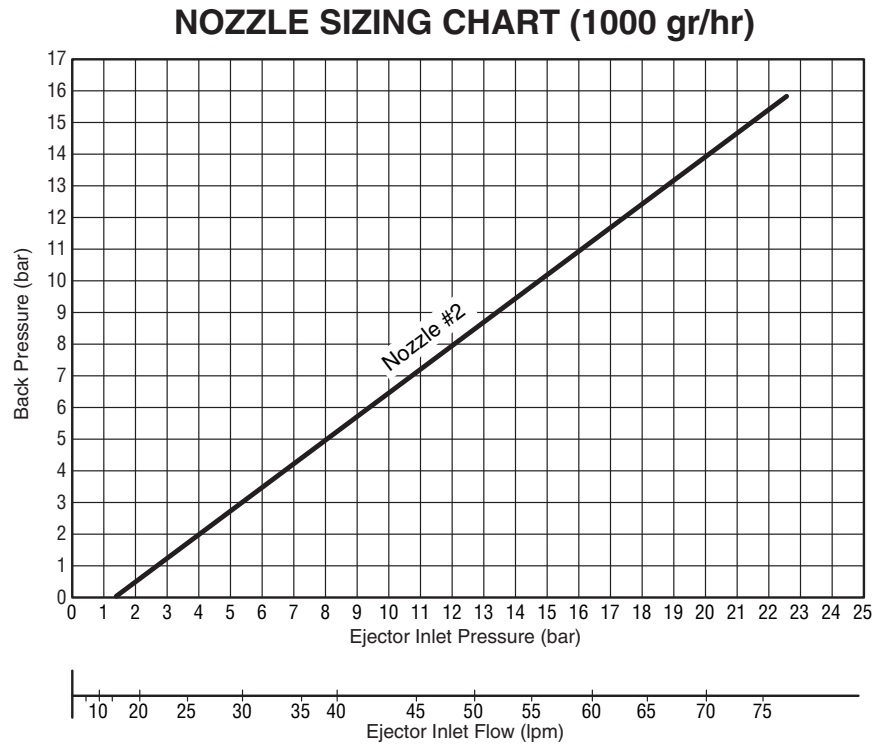
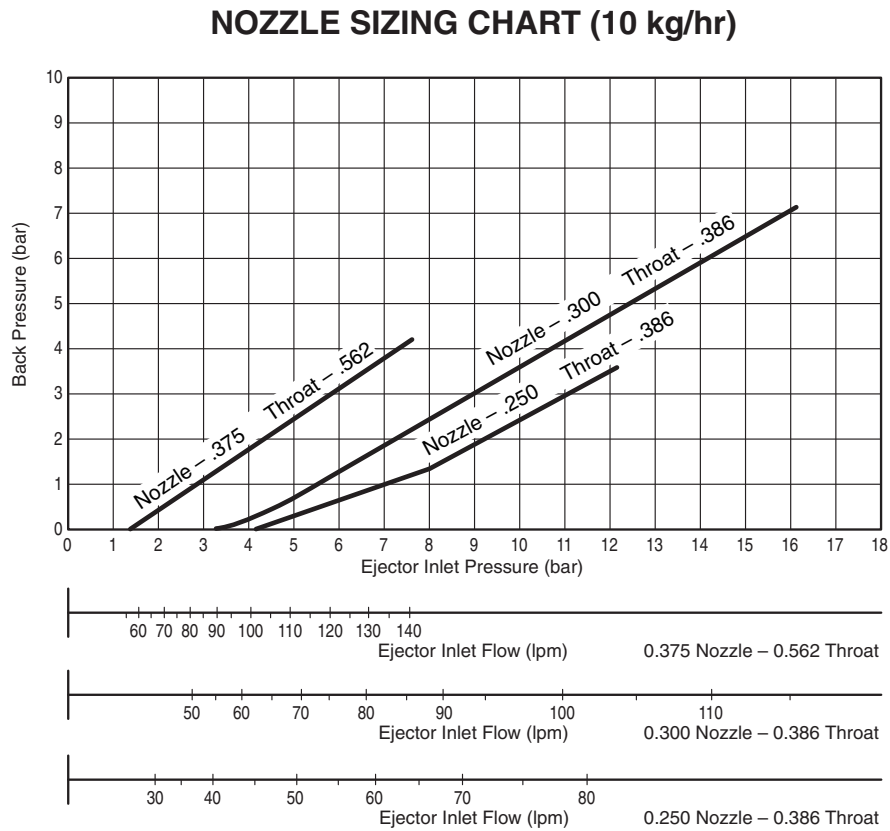
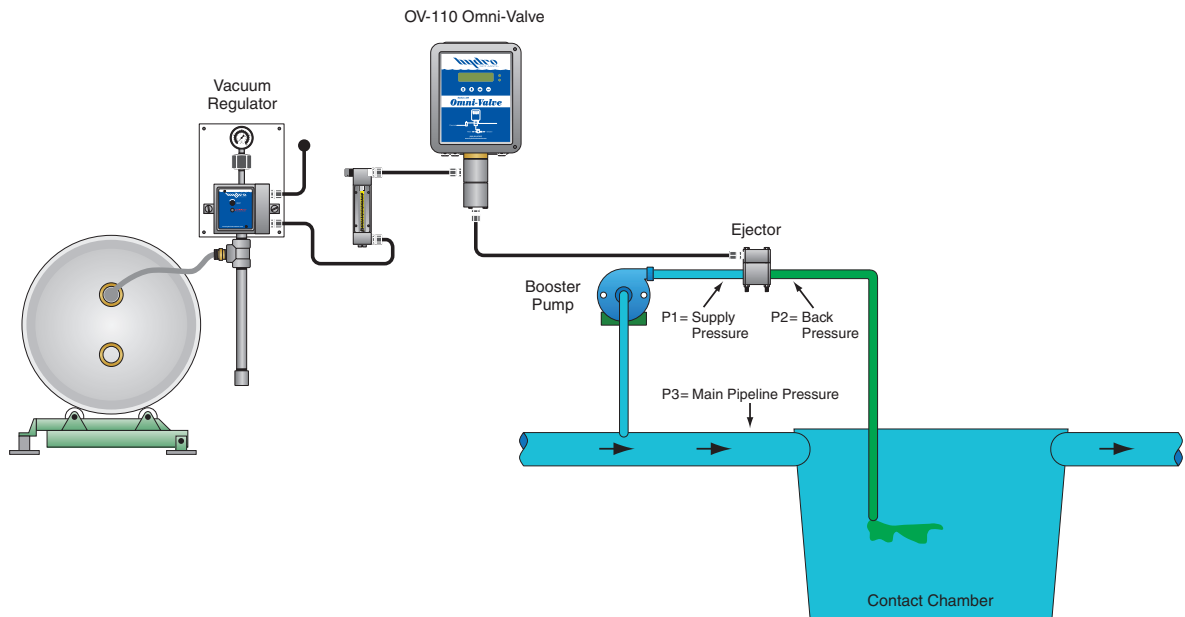

Figure 5: Standard ejector performance curve for the EJ-5000 Ejector (10 kg/hr).



2. Injection into an open tank (such as a contact chamber in a surface water plant):

Figure 6: Typical open tank installation with booster pump



- a. It is best to locate the ejector as close as possible to the contact chamber so that the back pressure P2 is as low as possible. Also, the installation will be safer if this section of pipe is shorter because the pipe contains highly concentrated chlorine under pressure.
- b. In this example, P3 = 1 bar, the contact chamber pressure is zero, and we will assume that the ejector is located within 10 meters of the contact chamber (therefore, we estimate that the back pressure P2 = 0.3 bar).
- c. In this example, Q = 4,000 m³/hr and Dosage = 2 PPM. Therefore, the required chlorine gas feed rate is 8 kg/hr because:
 $[4,000 \text{ (m}^3\text{/hr)}] \times [2 \text{ PPM}] \times [1/1000] = 8 \text{ kg/hr}$
 Therefore, we could select a 10 kg/hr Model EJ-5000 ejector.
- d. Looking at the 10 kg/hr ejector performance curve (See Figure 5 above) with the standard 0.300 nozzle, using the back pressure P2 = 0.3 bar, we can see that the minimum required supply pressure P1 = 4.5 bar and the minimum water flow rate is 65 liters/minute (3.9 m³/hr).
- e. Since the booster pump inlet pressure P3 = 1 bar and the required supply pressure P1 = 4.5 bar, the booster pump requirement is 3.5 bar (= 4.5 bar – 1 bar). The booster pump must produce a pressure boost of at least 3.5 bar when the booster pump flow rate is 3.9 m³/hr.
- f. From the ejector performance curve you can see that there are two other nozzle options that would have two different booster pump requirements. Therefore, there are three choices:
 0.250 Nozzle – Booster Pump requirements = 4 bar @ 3.0 m³/hr
 0.300 Nozzle – Booster Pump requirements = 3.5 bar @ 3.9 m³/hr
 0.375 Nozzle – Booster Pump requirements = 1 bar @ 4.2 m³/hr